

XC-2

Xcitex High-Speed Camera

1000 fps

Small and Rugged –
Easy Setup in Field or Lab



Lens sold separately

Features at a Glance

- Color or monochrome
- 1920 x 1080 pixel resolution
- High Definition
- Optimized for low light conditions
- Up to 1000 fps at reduced resolution
- CMOS image sensor
- Dynamic range up to 60 db (linear)
- Global shutter
- Compact size: 55 x 55 x 42 mm
- Configurable region of interest (ROI)
- Ultra-low trigger delay

Introducing the XC-2 – the next-generation high-speed camera from Xcitex for use with our acclaimed ProCapture motion capture systems. The XC-2 provides users with high definition for their application recordings. Select from a wide range of frame rates beginning at 5 fps up to a maximum of 1000 fps. The XC-2 also offers multiple resolution choices up to 1920 x 1080 pixels.

Optimized for low-light situations, the XC-2 is ideal for industrial applications where high sensitivity and high frame rates are required. The global shutter ensures that even high-speed applications with extremely short exposure times are captured.

The XC-2 camera has been designed to provide flexibility in creating a recording environment for your unique application needs. Using CMOS image sensor technology, the XC-2 delivers the perfect balance of light sensitivity, high recording speed, fast shuttering, and high resolution. Excellent image quality is achieved with a state-of-the-art 2.1 megapixel resolution sensor based on 5.5 μ m square pixels.

Frame Rate	Resolution
60 frames/sec	1920 x 1080
	1680 x 1050
	1152 x 864
	900 x 900
	720 x 1080
100 frames/sec	1920 x 900
	1260 x 1080
	1152 x 900
	900 x 900
150 frames/sec	720 x 1080
	1920 x 600
	1260 x 1080
	1152 x 864
250 frames/sec	720 x 720
	1920 x 360
	1152 x 720
500 frames/sec	720 x 360
	1920 x 180
	1260 x 360
1000 frames/sec	600 x 720
	1920 x 85
	900 x 175
	600 x 350

This chart is a sampling of frame rates/resolution specifications available from the XC-2 camera.

Contact

1-617-225-0080
info@xcitex.com

Technical Support

www.xcitex.com/html/support-services.php

Literature

www.xcitex.com/html/literature.php



FROM MOTION TO DATA TO KNOWLEDGE

Spectral response of XC-2 CMOS Image Sensor

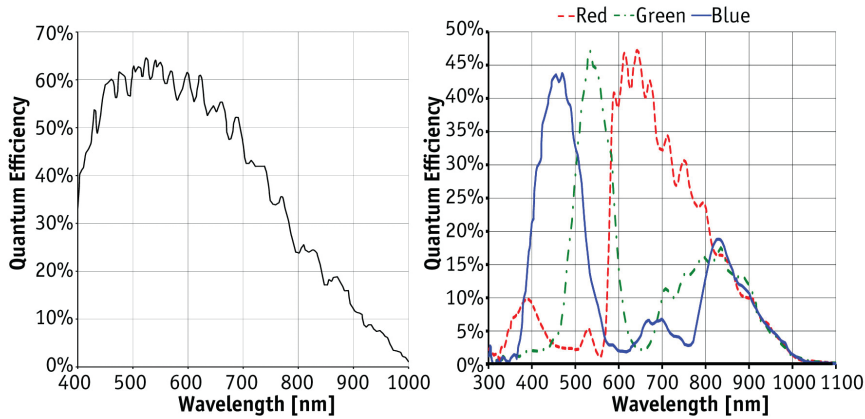

Image Sensor

Technology	CMOS active pixel (APS)
Scanning Systems	Progressive scan
Resolution (total)	1920 x 1080 pixels (maximum)
Pixel size	5.5 μm x 5.5 μm
Active Optical area	10.6 mm x 5.9 mm (maximum)
Spectral range	350 to 900 nm (at 10% of peak responsivity)
Shutter mode	Global shutter

Camera

Grayscale resolution	8 bit / 10 bit
Fixed pattern noise (FPN)	< 1 DN @ 8 bit / correction ON
Operating temperature	0°C to +50°C
Power	+12 V DC ($\pm 10\%$)
Power consumption	< 4.2 W
Dynamic Range	60 db
Conformity	CE / RoHS / WEEE
Optical format	2/3" (12.76 mm diagonal)
Lens Mount	C-mount (optional CS-mount)
Accessories included	Power supply and 7-meter cable

Dimensions

Dimensions	55 x 55 x 42 mm (w/o lens)
Weight	230 g / 8.1 oz.

Camera Dimensions

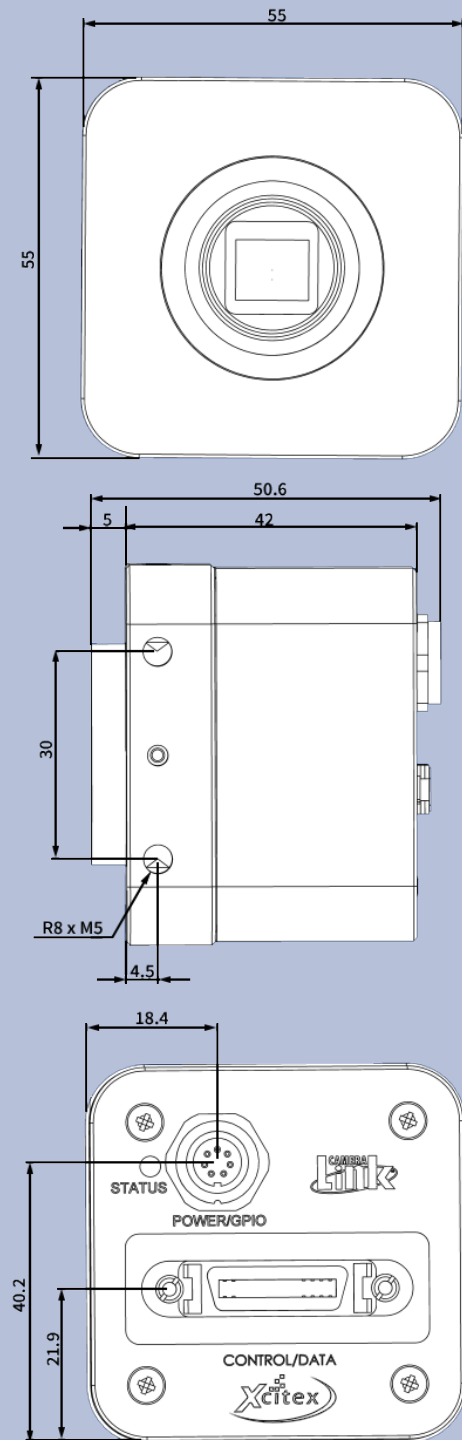

FROM MOTION TO DATA TO KNOWLEDGE

© Copyright 2018 Xcitex Inc. All rights reserved. Specifications subject to change without notice.
Xcitex Inc., Woburn, MA USA • 1-617-225-0080

www.xcitex.com

Xcitex Professional Motion System

Capture Analyze Share